

"QUALITY PUMPS SINCE 1939"

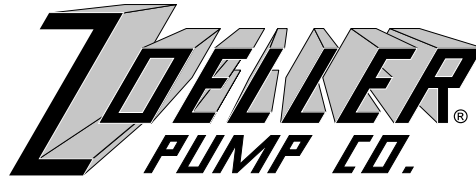

FM2408
0107
Supersedes
1106

Product information presented here reflects conditions at time of publication. Consult factory regarding discrepancies or inconsistencies.

**QWIK JON® ULTIMA 203 SYSTEMS
INSTALLATION INSTRUCTIONS
PREINSTALLATION CHECKLIST**

MODEL NO. _____
DATE CODE: _____
DATE INSTALLED: _____

1. Inspect all materials. Occasionally, products are damaged during shipment. If the unit is damaged, contact your dealer before using. **Do Not** remove the test plugs from the pump.
2. Carefully read all the literature provided to familiarize yourself with specific details regarding installation and use before attempting the installation. These materials should be retained for future reference.

 <div style="border: 1px solid black; padding: 5px; display: inline-block;">WARNING</div> <p>SEE BELOW FOR LIST OF WARNINGS</p>	<div style="border: 1px solid black; padding: 5px; display: inline-block;">CAUTION</div> <p>SEE BELOW FOR LIST OF CAUTIONS</p>
---	---

1. **To help reduce the risk of electrical shock**, a properly grounded receptacle or control box of grounding type must be installed and protected by a ground fault circuit interrupter (GFCI) in accordance with the National Electrical Code and applicable local codes. **Never remove ground pin from plug.** If pump is wired direct, a GFCI must be installed in the control box. **(SEE WARNING BELOW)**
2. Make certain that the ground fault interrupter protected receptacle or control box is within reach of the pump's power supply cord. **DO NOT USE AN EXTENSION CORD.** Extension cords that are too long or too light do not deliver sufficient voltage to the pump motor. But more important, they could present a safety hazard if the insulation were to become damaged or the connection end were to fall into a damp or wet area.
3. **Make sure the pump's electrical supply circuit is equipped with fuses or circuit breakers of proper capacity.** A separate branch circuit, sized according to the National Electrical Code for the current shown on the pump name plate is recommended. (See Note 3.)
4. **TESTING FOR GROUND.** As a safety measure, each electrical outlet should be checked for ground using an Underwriters Laboratory Listed circuit analyzer which will indicate if the power, neutral and ground wires are correctly connected to your outlet. If they are not, call a qualified licensed electrician.
5. **FOR YOUR PROTECTION ALWAYS DISCONNECT PUMP FROM ITS POWER SOURCE BEFORE HANDLING.** If pump is wired direct, **de-energize the circuit at the control box.** Grounded pumps are supplied with a 3-prong grounded plug to help protect you against the possibility of electrical shock. **DO NOT UNDER ANY CIRCUMSTANCES REMOVE THE GROUND PIN.** To reduce the risk of electrical shock, a properly grounded receptacle or control box of grounding type must be installed and protected by a ground fault circuit interrupter (GFCI) in accordance with National Electrical Code and applicable local codes.
6. Installation and checking of electrical circuits and hardware should only be performed by a qualified licensed electrician.
7. According to the state of California (Prop 65), this product contains chemicals known to the state of California to cause cancer and birth defects or other reproductive harm.

1. This unit is not designed to handle any material other than human waste and toilet paper. The following list includes examples, but is not limited to, items that should **not** be used with this system: Feminine sanitary products, condoms, cotton balls and swabs, baby wipes, paper towels, etc.
2. Check to be sure your power source is adequate to handle the amperage requirements of the motor as indicated on the pump or unit I.D. tag.
3. All plumbing (discharge and vent lines) must be installed to meet local codes. **Unit must be vented. Do not use an automatic plumbing vent device. Toilet will not flush.**
4. Maximum continuous operating temperature for model 203 must not exceed 110°F (43°C).
5. Do not use cleaning products containing bleach in the toilet tank, toilet or attached fixtures as they will degrade the pump seals.



NOTES

SEE BELOW FOR LIST OF NOTES

1. Repair and service should be performed by an Authorized Service Station only. (Consult Factory.)
2. NOTE: Recommended for installations up to 20' total dynamic head. Consult Factory if installation is above 15' vertical height in 1" pipe. Mini-Grinder Pump is designed for use in Qwik Jon® Ultima units only. It is not designed for use in any other application.
3. Mini-grinder pump is rated for 115V, 60 Hz, 7 Amps, .5 HP.
4. NOTE: Pumps with the "UL" mark and pumps with the "US" mark are tested to UL Standard UL778. CSA Certified pumps are certified to CSA Standard C22.2 No. 108. Qwik Jon® Ultima units only. It is not designed for use in any other application.

REFER TO WARRANTY ON PAGE 2.

P/N 018509

Limited Warranty

Manufacturer warrants, to the purchaser and subsequent owner during the warranty period, every new product to be free from defects in material and workmanship under normal use and service, when properly used and maintained, for a period of one year from date of purchase by the end user, or 18 months from date of original manufacture of the product, whichever comes first. Parts that fail within the warranty period, one year from date of purchase by the end user, or 18 months from the date of original manufacture of the product, whichever comes first, that inspections determine to be defective in material or workmanship, will be repaired, replaced or remanufactured at Manufacturer's option, provided however, that by so doing we will not be obligated to replace an entire assembly, the entire mechanism or the complete unit. No allowance will be made for shipping charges, damages, labor or other charges that may occur due to product failure, repair or replacement.

This warranty does not apply to and there shall be no warranty for any material or product that has been disassembled without prior approval of Manufacturer, subjected to misuse, misapplication, neglect, alteration, accident or act of God; that has not been installed, operated or maintained in accordance with Manufacturer's installation instructions; that has been exposed to outside substances including but not limited to the following: sand, gravel, cement, mud, tar, hydrocarbons, hydrocarbon derivatives (oil, gasoline, solvents, etc.), or other abrasive or corrosive substances, wash towels or feminine sanitary products,

etc. in all pumping applications. The warranty set out in the paragraph above is in lieu of all other warranties expressed or implied; and we do not authorize any representative or other person to assume for us any other liability in connection with our products.

Contact Manufacturer at, 3649 Cane Run Road, Louisville, Kentucky 40211, Attention: Customer Service Department to obtain any needed repair or replacement of part(s) or additional information pertaining to our warranty.

MANUFACTURER EXPRESSLY DISCLAIMS LIABILITY FOR SPECIAL, CONSEQUENTIAL OR INCIDENTAL DAMAGES OR BREACH OF EXPRESSED OR IMPLIED WARRANTY; AND ANY IMPLIED WARRANTY OF FITNESS FOR A PARTICULAR PURPOSE AND OF MERCHANTABILITY SHALL BE LIMITED TO THE DURATION OF THE EXPRESSED WARRANTY.

Some states do not allow limitations on the duration of an implied warranty, so the above limitation may not apply to you. Some states do not allow the exclusion or limitation of incidental or consequential damages, so the above limitation or exclusion may not apply to you.

This warranty gives you specific legal rights and you may also have other rights which vary from state to state.

Helpful Hints For Easy Installation

1. Read all instructions before beginning installation.
2. Be sure the floor is level within 1/8".
3. Install vent pipe seal with flange side of seal on outside of lid.
4. Use soapy water to lubricate all seals to aid installation.
5. Install rubber coupling/union in vent line to aid disassembly.
6. Do not over torque toilet mounting screws.
7. Do not use an automatic plumbing vent device.
8. Obtain model number and date code, and record information in the space provided on the front of this manual. Refer to this information when calling Factory.

Do's And Don't's For Installing A Unit

1. DO read all installation material with the unit.
2. DO inspect unit for any visible damage caused by shipping. Contact dealer if unit appears to be damaged.
3. DO clean all visible debris from the unit.
4. DO always disconnect pump from power source before handling. DO always connect to a separately protected and properly grounded ground fault protected circuit. DO NOT ever cut, splice or damage power cord. DO NOT carry or lift pump by its power cord. DO NOT use an extension cord.
5. DO install a union in the discharge line.
6. DO test pump immediately after installation to be sure that the system is working properly.
7. DO review all applicable local and national codes and verify that the installation conforms to each of them.
8. We DO NOT recommend this product be connected to utilities other than those found in a normal bathroom application. Washing machines and dishwashers are examples of equipment that we Do Not recommend.
9. DO inspect and test system for proper operations at least every 3 months.

Typical Piping Configurations

NOTE: All installations must comply with all applicable Electrical and Plumbing Codes, including, but not limited, to National Electrical Code; Local; Regional and/or State Plumbing Codes, etc.

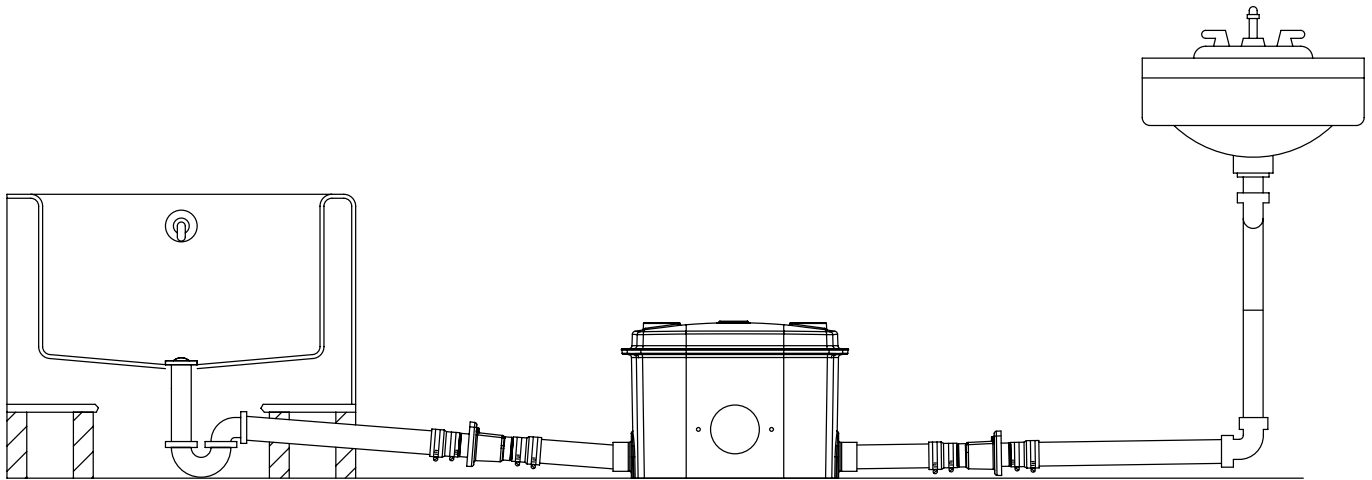

SK2612

Service Parts

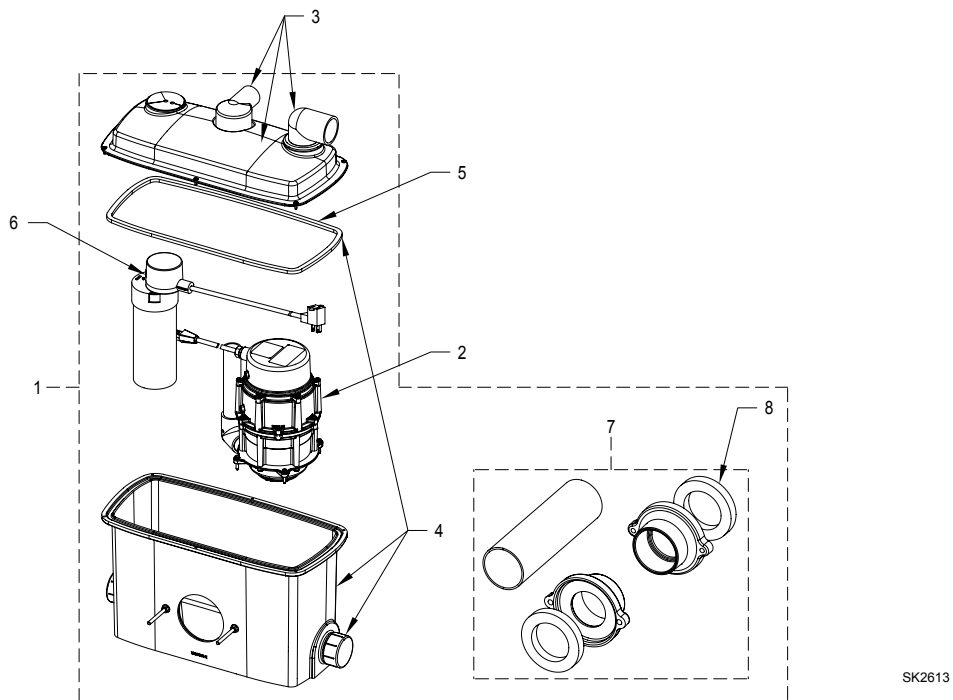

SK2613

Item	Description	Part No.
1	Qwik Jon Ultima Model 203 Sewage Removal System	203-0005
2	N202RP replacement pump with discharge pipe	017374
3	Tank cover with discharge fittings	017373
4	Tank	018513
5	Seal	017350
6	Float switch assembly	018501
7	Flange extension kit	018510
8	Closet seal	017347

Condition	Possible Cause	Remedy
A. PUMP WILL NOT START OR RUN.	Low voltage, blown fuse open circuit.	Have a qualified electrician check fuse and circuit.
	Impeller bound.	Contact a Zoeller Service Station.
	Motor or wiring shorted.	
	Debris on float switch.	Remove debris
B. PUMP STARTS TOO SOON.	Float "ON" point is adjusted too low.	Raise the float stops, make sure the float is between the two stops.
C. WATER LEVEL EXCESSIVE BEFORE PUMP TURNS ON.	Float "ON" point adjusted to high.	Lower the upper float stop.
D. PUMP WILL NOT SHUT OFF OR RUNS TOO LONG BEFORE WATER IS PUMPED.	Debris under float.	Remove debris from around float.
	Faulty float switch.	Contact a Zoeller Service Station.
	Float "Off" point adjusted too low.	Raise the lower float stop.
	Pump is air locked.	Make sure vent hole in discharge pipe is clear.
	Water level too low.	Raise the lower float stop.
	Waste material has accumulated blocking flow of material.	Hold flush handle down on toilet for 15 seconds. If unit will not clear, unplug and wait 30 minutes. Plug unit back in and repeat. If unit still will not turn off, it will need to be opened and the debris relocated.
E. PUMPOPERATESBUTDELIVERS LITTLE OR NO WATER.	Debris around intake.	Clean area around intake.
	Blockage in discharge pipe.	Remove pipe and flush out debris.
	Low or incorrect voltage.	Have a qualified electrician check house wiring.
	Damaged Impeller.	Contact a Zoeller Service Station.
	Incorrect float adjustment.	Contact Technical Service Department.
	Pump is air locked.	Make sure vent hole in discharge pipe is clear.
	Vertical lift too high.	Change discharge piping or contact tech. service.



▲ WARNING Before servicing a pump, always shut off the main power breaker and then unplug the pump - making sure you are not standing in water and are wearing insulated protective sole shoes. Under flooded conditions, contact your local electric company or a qualified licensed electrician for disconnecting electrical service prior to pump removal.

▲ WARNING Submersible pumps contain oil which become pressurized and hot under operating conditions -allow 2½ hours after disconnecting before attempting service.

If the above checklist does not solve the problem, consult Zoeller Technical Service Department 1-(800) 928-PUMP - **Do not** attempt to service or otherwise disassemble pump.

▲ CAUTION Do not dispose of feminine sanitary products, disposable diapers, dish rags, etc. in the QWIK JON® ULTIMA . They may jam the pump or other plumbing lines and cause malfunction.

CARE OF FINISH: Soap and water is all that is recommended for cleaning the outside of the tank. Other cleaning products may cause discoloration and scratching.

Qwik Jon Ultima Qwik Reference Guide

STEP 1

Location Selection

Plan your new installation carefully.

Floor: The floor should be structurally sound and level within 1/8". If the floor is not level, use hydraulic cement or similar material to level the floor.

Water: A water supply will be needed to operate the toilet. Usually a 1/2" line with a shut-off valve is sufficient.

Electrical: A 115 volt GFCI receptacle will be needed to supply electrical power to the pump.

Sewage: Access to a sewage line is required. The Qwik Jon Ultima requires a 1" (or 3/4" if your codes permit) sewage discharge line to connect to an existing sewage line.

Vent: Access to a vent pipe is required. The use of a mechanical vent system is NOT recommended as the toilet will not flush.

NOTE: If a built-in installation is to be used, locate the pump unit in an area that will allow access to the pump and switch.

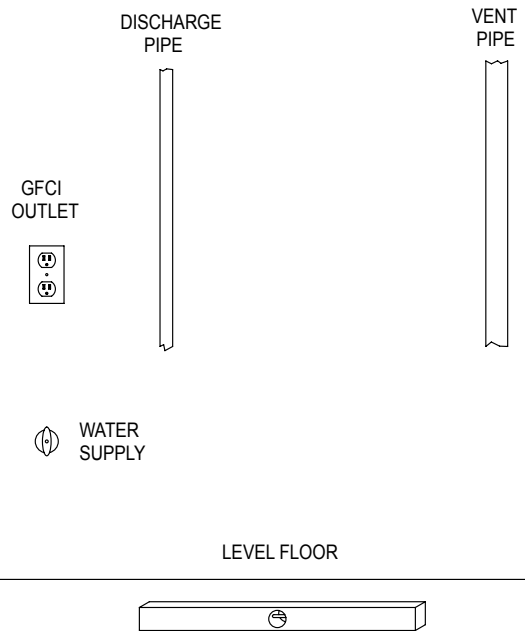

SK2588

STEP 2

Leveling of Pump Unit

CAUTION Do not use wooden shims to level the pump unit!

CAUTION Ensure that nails, screws or other sharp objects do not puncture the pump unit!

Level the pump unit to within 1/8" using hydraulic cement or similar material.

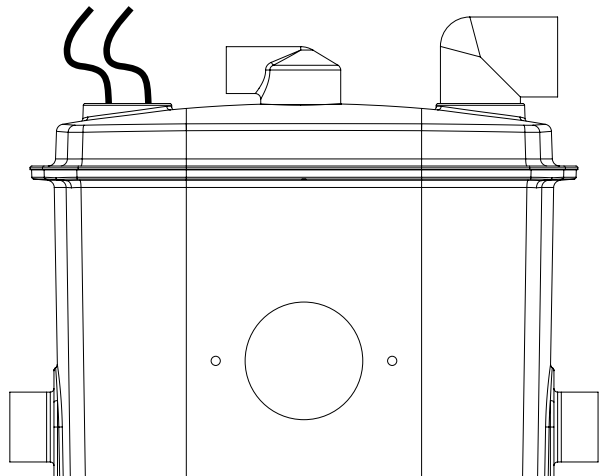

SK2614

STEP 3

Rough-in (stand alone installation)

- 1) Connect the toilet bowl to the pump unit with the closet seal as shown.
- 2) Position the pump unit a minimum of 1/8" from the wall.
- 3) Lightly mark the closet bolt locations on the floor. Set tank/toilet bowl assembly to the side and install closet bolts at the points marked earlier.
- 4) Place toilet assembly over closet bolts. Install the anchoring hardware and tighten in an alternating pattern. Check for level and shim as required. Be careful when tightening bolts or nuts against china to avoid cracking the china.

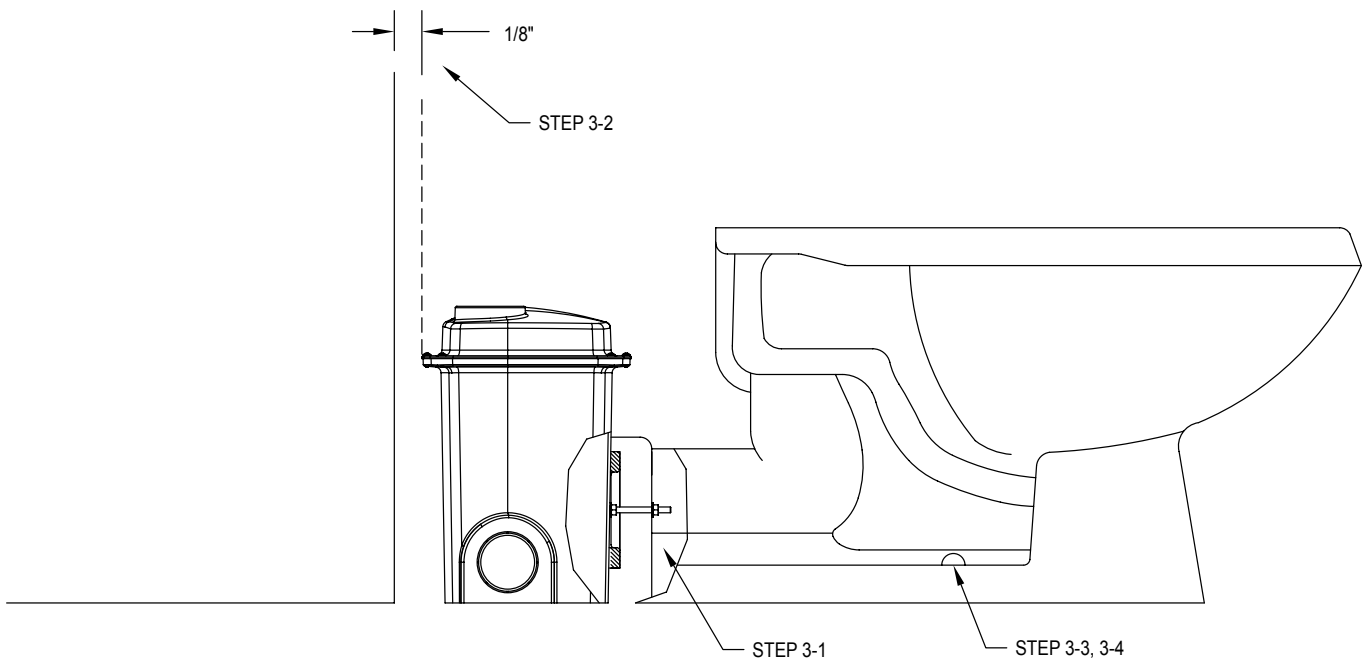

SK2615

STEP 4

Rough-in (built-in installation)

- 1) Attach flange extension with closet seal onto toilet bowl as shown at right.
- 2) Slide bowl up to wall and mark wall in order to connect to opposite side. Mark location for closet bolts. Remove bowl and set aside. Install closet bolts at locations previously marked.
- 3) Attach other flange extension with closet seal onto pump unit on opposite side of wall.
- 4) Cut 3" schedule 40 PVC pipe to the appropriate length in order to connect pump unit to toilet. Maximum recommended length is 18 inches. Once all piping is dry-fit per step 5, clean, prime, and solvent weld the 3" PVC pipe into the flange extension.

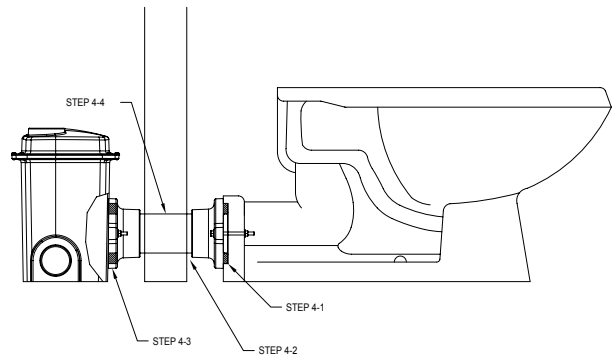

SK2616

STEP 5

Piping

- 1) Cut and dry-fit the pipe and fittings as required for 1" diameter discharge pipe (may be reduced to 3/4" diameter if codes permit).
- 2) While dry-fitting the discharge pipe, position and mark the location of the pump unit discharge fitting.
- 3) Cut and dry-fit 1-1/2" vent pipe as required to ensure that the vent pipe does not interfere with other components. Make the connection to the pump unit with the provided street elbow. A 2" x 1" 90° discharge fitting and a 1 1/2" street elbow have been provided, however, it may be easier to pipe straight up depending on the installation.
- 5) Clean, prime and solvent weld the discharge piping and pump unit discharge fitting.
- 6) Clean and solvent weld vent piping as required for proper venting.

CAUTION Proper venting is required for the toilet to flush. Do not use a mechanical type vent.

CAUTION When applying solvent weld to discharge fitting, ensure that none gets into the check valve assembly (see Figure 5.3). Pay close attention to the proper alignment of the discharge fitting previously marked above.

Note: Adding other bathroom fixtures - The Qwik Jon Ultima is designed to accept additional bathroom fixtures utilizing the two side inlets. These inlets can be attached via the 2" MPT (outside diameter) or the 1 1/2" slip (inside diameter). These inlets must have the inner portion drilled out using a 1 1/4" hole saw (see Figure 5.2). This is to ensure there is no leakage problems from inlets not in use. When utilizing side inlets, install a check valve on the incoming line.

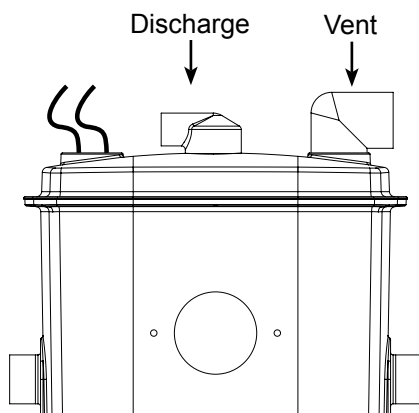

Figure 5.1

SK2614

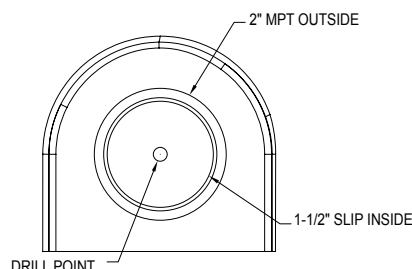

Figure 5.2

SK2586

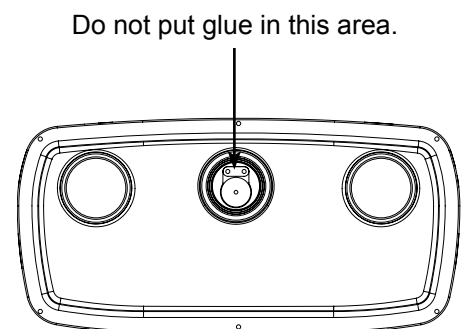

Figure 5.3

SK2591

STEP 6

Toilet Installation

- 1) Install toilet tank per manufacturer's instructions.
- 2) Install the anchoring hardware and tighten in an alternating pattern. Check for level and shim as required. Be careful when tightening bolts or nuts against china to avoid cracking the china.
- 3) Install the water supply line from the existing water shut-off valve to the toilet water supply connection.
- 4) Open the water supply valve and check for leaks. The toilet tank should fill to the proper level. Adjust if required.
- 5) Plug the pump's power cord into the piggyback switch receptacle and then plug the piggyback switch into the GFCI outlet.
- 6) Flush the toilet and watch for proper operation. Listen for the pump to start. The pump unit requires proper venting in order for toilet to flush. Check for leaks.
- 7) Repeat flush cycles to assure proper operation.
- 8) Install an elongated toilet seat (supplied by others).
- 9) Install the lid on the toilet tank.



ZOELLER
PUMP CO.

Manufacturers of . .

"QUALITY PUMPS SINCE 1939"